

We can plan your room for you. Just download this simple guide, fill it in and email us your sizes and we will create and send you back elevations of how your room could look like. Remember to send contact details in case we need to ask you questions. Also any information, like style and colour of the doors, worktops and all appliances needed in the room even if they are your own! Email to: legacykbb@gmail.com

# GETTING THE MEASURE OF YOUR ROOM

The first step to getting that dream kitchen is to record all the dimensions and features of your room-space. From these our consultants in conjunction with you can lay out a plan

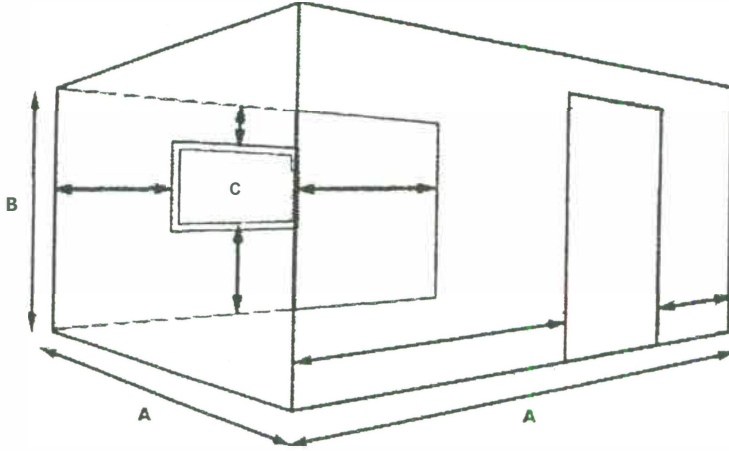

The first step is to measure all the walls from corner to corner (A), marking on your plan anything that projects into the room or recesses out. Measure the ceiling height (B) and clearly mark any changes in that height.

Next measure the sizes of any windows, followed by their height from the floor and distance from the corners of the room (C). Also clearly mark the positions of any doors and the direction in which they open.

Measure and mark on your plan all fixed utility points such as gas, water and waste.

Measure and mark the position of items such as radiators and central heating boilers

Finally mark any existing electrical and phone points

Remember! The more information the better.

